

SINGLE & TWIN IMPELLER "FIREFIGHTER®"
BARE SHAFT PUMPS
Model Numbers: 5150P & 5250P

DEPEND ON
DAVEY

WATER PRODUCTS



SELF PRIMING PUMPS

PRODUCT DESCRIPTION

Rugged, economical, single and twin impeller centrifugal self priming pumps. Designed to be direct coupled to an engine or electric motor, or belt driven.

APPLICATIONS

- Firefighting
- Tank filling
- Irrigation
- Garden watering
- Water transfer
- Crop spraying

FEATURES & BENEFITS

Patented clamped impeller design to enable longer impeller life, improved performance and easier disassembly in the case of blockage.

Thrust balanced impeller design to extend bearing life.

Pump casing, diffusers and impellers manufactured from quality corrosion resistant marine grade aluminium for long life.

4 way discharge port for easy installation with a choice of plumbing sizes.

Epoxy coated pump casing, exterior and interior, for added corrosion resistance.

Patented floating impeller neckrings front and back. The front neckring helps improve pumping efficiency, the back neckring helps extend seal life and dramatically reduce bearing load.

Self priming from 8m for more versatile installation options.

Large priming and drain port with bayonet fit plugs. Plugs have safety retention system, plus are available with 1/4" tapping to accept pressure gauges or drain cocks.

Viton seal and oring kit available for herbicide/insecticide spraying.

OPERATING LIMITS

	5150P	5250P
Flows to	560lpm	470lpm
Max. total head	76m	120m
Max. suction Lift	8m	7m
Max. pump speed	4250rpm	
Max. water temperature	50°C	
Min. water temperature	1°C	
Min. suction pipe size	1 1/2"	
Suction pipe strainer	Required	
Inlet size	1 1/2" BSP(M)*	
Outlet sizes	2 x 1 1/2" BSP(M)* 2 x 1" BSP(M)*	

* NPT thread available on request.



TECHNICAL SPECIFICATIONS

MATERIALS OF CONSTRUCTION

PART	MATERIAL
Suction cover	Marine grade aluminium (AS605)
Diffuser	Marine grade aluminium (AS605)
Impeller	Marine grade aluminium (AS605)
Casing / yoke	Marine grade aluminium (AS605)
Bearing housing	Marine grade aluminium (AS605)
Pump shaft	303 Stainless steel
Mechanical seal	Carbon / ceramic
4 way discharge	Marine grade aluminium (AS605)
Casing bolts	Zinc plated steel
Yoke bolts	Stainless steel
Flap valve / seal ring	Zinc body, Hytrel seal
Neck ring, priming & drain plug	Glass filled Nylon
Casing, priming & drain plug oring	Nitrile rubber

HYDRAULIC PERFORMANCE

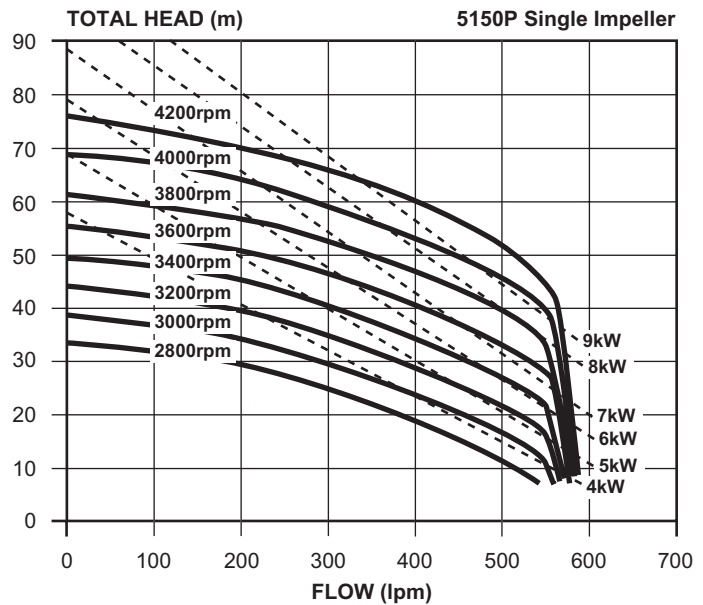

DIMENSIONS

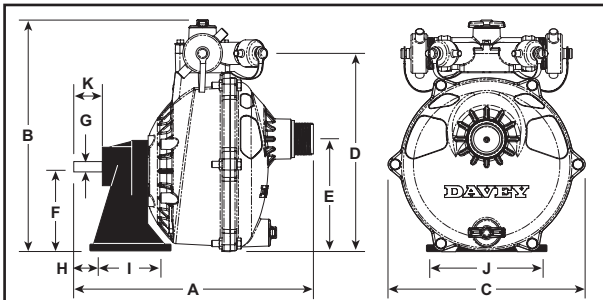

Model	A	B	C	D	E	F	G	H	I	J	K	Inlet BSP	Outlet BSP	Net Wght kg.
5150P	378	347	298	169	296	115.8	19.05	29	82.5	146.1	69	1 1/2"	2x1" 2x1 1/2"	6
5250P	448	347	298	169	296	115.8	19.05	29	82.5	146.1	69	1 1/2"	2x1" 2x1 1/2"	8

Key size: 3/16" (W) x 3/16" (D) x 1 1/4" (L). Mounting holes: 4x10mm. All dimensions in mm unless otherwise stated.

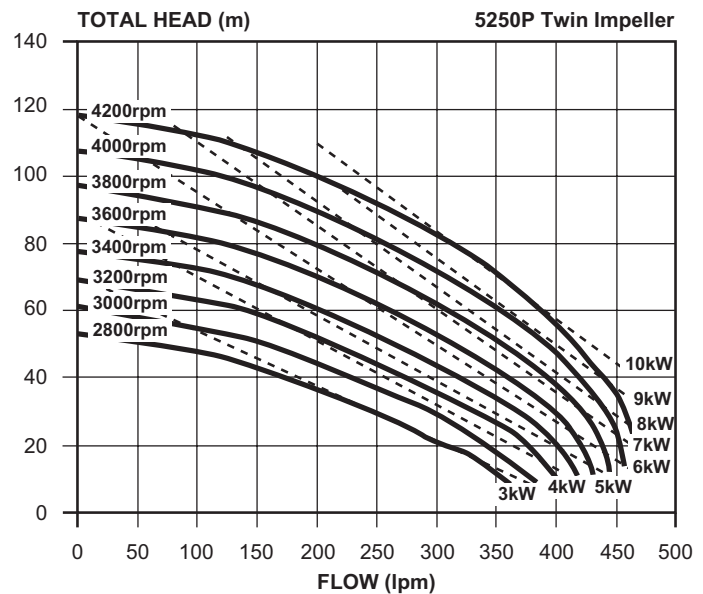

INSTALLATION & PRIMING

- Power output of chosen prime mover should be 15% more than the maximum required by the pump for speed selected (see performance curve). This is to allow for transmission losses.
- Mount pump and prime mover on substantial common base.
- A 2 piece coupling with resilient joiner drive is recommended. Do not use rigid sleeve coupling.
- Fit strainer to bottom of suction pipe; a foot valve is **not** required.
- To prime, fill pump body with water then allow pump to run until drawing water.

This literature is not a complete guide to product usage. Further information is available from your Davey dealer, Davey Customer Service Centre and from the relevant product installation and Operating Instructions. This data sheet must be read in conjunction with the relevant product Installation and Operating Instructions and all applicable statutory requirements. Product specifications may change without notice.

© Davey and Firefighter are registered trademarks of Davey Products Pty Ltd. © Davey Products Pty Ltd 2004.



Visit Davey on-line for further information
www.davey.com.au

DEPEND ON
DAVEY

WATER PRODUCTS

Davey Products Pty Ltd

Member of the GUD Holdings Ltd Group
 ABN 18 066 327 517
 Head Office and Manufacturing
 6 Lakeview Drive,
 Scoresby, Australia 3179
 Ph: +61 3 9730 9222
 Fax: +61 3 9753 4100
 Website: www.davey.com.au
 Customer Service Centre
 Ph: 1300 367 866
 Fax: 1300 369 119
 E-mail: sales@davey.com.au
 Interstate Offices
 Sydney - Brisbane - Adelaide
 Perth - Townsville

International
 6 Lakeview Drive,
 Scoresby, Australia 3179
 Ph: +61 3 9730 9121
 Fax: +61 3 9753 4248
 E-mail: export@davey.com.au

Germany
 Kantstrasse 47,
 04275 Leipzig
 Ph: +49 341 301 0412
 Fax: +49 341 301 0413
 E-mail: akrenz@daveyeurope.com

New Zealand
 2 Rothwell Avenue,
 North Harbour, Auckland 1330
 Ph: +64 9 914 3680
 Fax: +64 9 914 3685
 Website: www.daveynz.co.nz
 E-mail: sales@daveynz.co.nz

USA - Davey Pumps Inc.
 1005 N. Commons Drive
 Aurora, Illinois 60504
 Ph: +1 630 898 6976
 Fax: +1 630 851 7744
 Website: www.daveyusa.com
 E-mail: sales@daveyusa.com