



Ultimate Unit Bearing

General Description

Built ground up with Ultra4 rock racers in mind, the Spidertrax Ultimate Unit Bearing is truly the reinvention of the unit bearing itself. Genuine Timken bearings, full chromoly heat treated construction, and a fully integrated drive slug makes the Ultimate Unit Bearing the only racing unit bearing of its kind. Proudly designed & manufactured in Loveland, Colorado.

When installing the Ultimate Unit Bearing, please note these following tips:

1. When assembling on a rear Spidertrax 1 Ton Full Floater End Cup Kit (Model No: UEC001, UEC002) purchased prior to 1-Aug-2012, the Lock Ring Retainer Bolts (Fig. 1) will contact the bottom of the Full Floater End Cup, preventing the Ultimate Unit Bearing from mounting flush. To remedy this interference, simply sand down the heads of the Lock Ring Retainer Bolts approximately 1/16" so as to prevent interference.
2. Because splines in Ultimate Unit Bearing run dry (non lubricated), it is CRITICAL the spline contact area has anti-seize applied liberally prior to installation of axle shaft. While many anti-seize brands will work, we recommend an ARP Ultra-Torque Assembly Lubricant (#100-9910). If you don't have a container of this in your workshop, treat yourself; it's well worth the investment.

Spidertrax Disclaimers & Warranty Card is located on the back of these instructions.

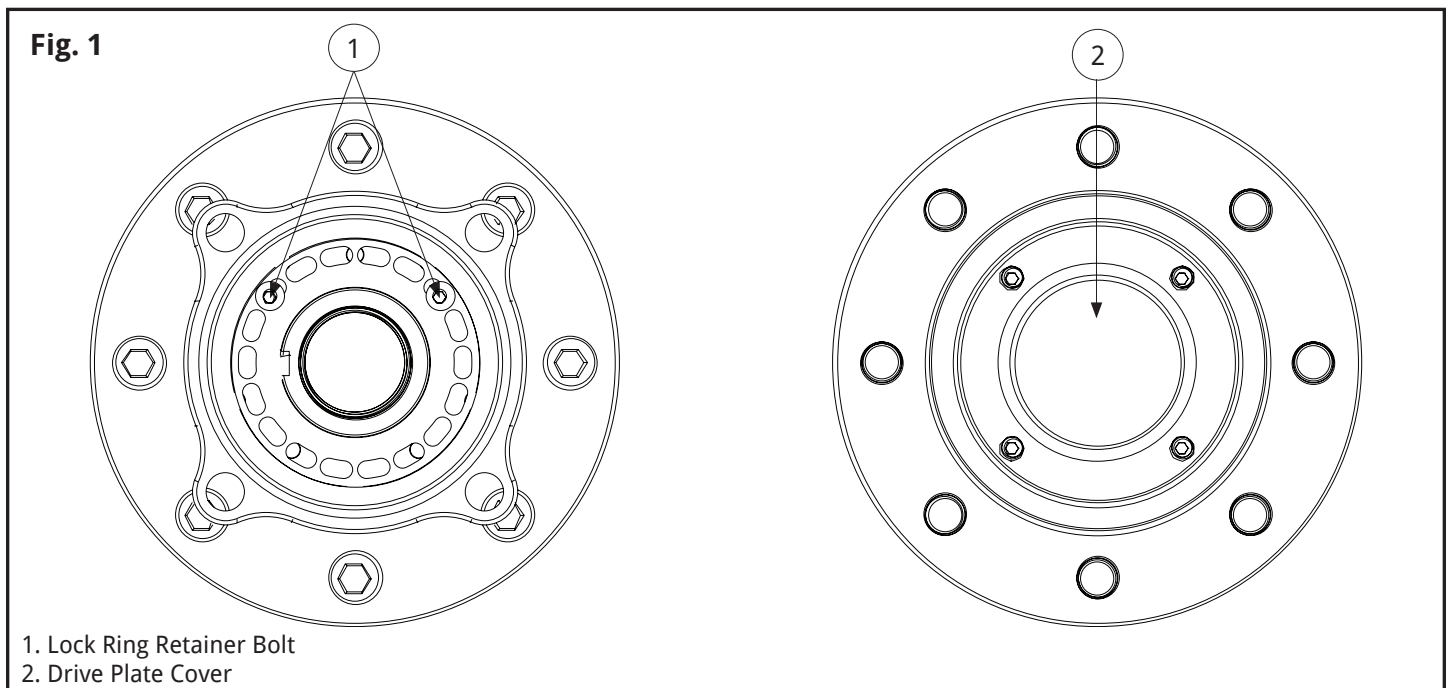



SPIDERTRAX
OFF-ROAD

Disclaimers & Warranty

WARNING

INSTALLATION OF ANY COMPONENT OR SYSTEM SHOULD ONLY BE PERFORMED BY THOSE EXPERIENCED IN AUTOMOTIVE MECHANICS AND PROCEDURES.

Spidertrax warrants only to the original purchaser that all products will be free from defects in materials and workmanship. The foregoing warranty is subject to the proper installation, operation and maintenance of the product in accordance with the installation instructions supplied. Warranty claims must be made by the purchaser in writing within 30 days of the manifestation of a problem and purchaser must present acceptable proof of original ownership (such as copy of original receipt). Spidertrax reserves the right, before having any obligation under this Limited Lifetime Warranty, to inspect the damaged product and all costs of shipping the product to Spidertrax for inspection shall be borne solely by the purchaser. Spidertrax's sole obligation under the foregoing warranty is, at Spidertrax's option, to repair, replace or correct any such defect that was present at the time of delivery. The foregoing warranty is not transferable to another party and does not apply to any purchaser who bought the product from a reseller or distributor not authorized by Spidertrax.

FOR OFF-ROAD USE ONLY

DRIVE THE VEHICLE UNDER CONTROLLED CONDITIONS TO ENSURE PROPER INSTALLATION OF COMPONENTS. GRADUALLY WORK UP TO FOUR WHEELING SPEEDS.



Ultimate Unit Bearing Installation Instructions

ISTFUB0XX-13